

Split 11000



FROZEN ICE



Modular ice maker - Scale system
Daily production 5000 kg

• Position n°



• Application fields

Hotel	●●●●●●●●	Fish market	●●●●●●●●
Restaurant	●●●●●●●●	Supermarket	●●●●●●●●
Fast food	●●●●●●●●	SPA	●●●●●●●●
Bar	●●●●●●●●	Medical	●●●●●●●●
Disco	●●●●●●●●	Industry	●●●●●●●●

• Features & Plus

- Subcooled flakes (from -5°C to -10°C)
- 1 m³ = 430 kg of ice
- Low consumption (1 liter water / 1 kg ice)
- AISI 304 SS Scotch Brite finish
- Evaporator anticorrosion alloy made, with rotating knife
- Cleanable antiscaling filter
- Easy cleaning thanks to rounded surfaces
- FDA approved -ABS plastic components
- Conformity to RoHS directive
- Automatic water charge
- Standard and special voltages
- Model in Tropical Class + 43 ° C

2 Years Warranty

subject to limitations

• Certifications available for this model



www.ntfice.it
info@ntfice.it



ntfice.it





Modular ice maker - Scale system
Daily production 5000 kg

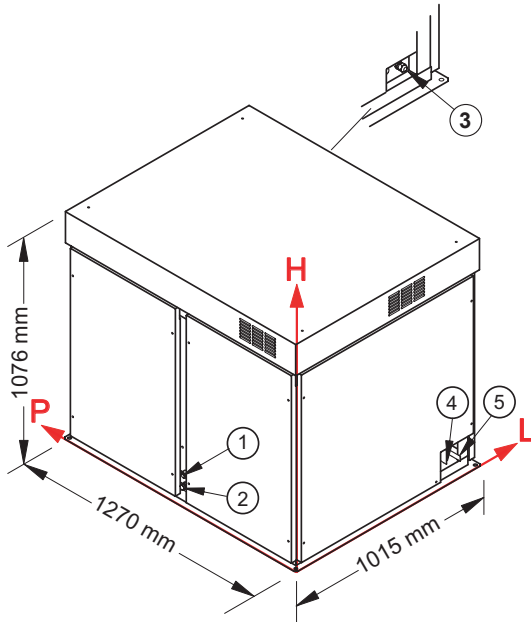

• Connections

All measures are referred to the rear bottom-left corner (L-H-Ø)

- ① Water inlet:
123 mm - 120 mm - 3/4"
- ② Water outlet:
78 mm - 65 mm - 24 mm
- ③ Electrical connection
- ④ Refrigerant feeding pipe
- ⑤ Outlet pipe of gaseous refrigerant

• Working conditions

- Location: Indoor

	Min	Max
Ambient temperature	+10° C	+43° C
Water temperature	+3° C	+32° C
Voltage	-10%	+10%
Water inlet pressure	1bar (14 psi)	6bar (84 psi)

• Technical information

Production in 24h	5000 kg
Refrigerant	R404A - R507 - R448A - R449A - R407F - R452A
Refrigerant capacity	25000 W (evap. temp. -27° C)
Standard voltage	400-415 V ~ 3N 50 Hz
Electrical consumption	360 W
Sizes (L-P-H mm)	1270 - 1015 - 1076
Sizes with pack (L-P-H mm)	1394 - 1139 - 1420
Net weight	600 kg
Gross weight	620 kg
Finish	AISI 304 stainless steel, scotch brite

All the technical information must be considered at the following conditions:



Refrigerant capacity
25000 W
(evap. temp. -27° C)



Water temperature
+15° C



Electrical consumption
at +43° C
(standard voltage)

Models and specifications are subject to change without notice
Rev. 02 - Issued September 2019

