

# SLT 170



# FROZEN STONE



Self-contained ice maker - Pebble system  
Daily production up to 96 kg

### • Position n°



### • Application fields

|            |            |             |            |
|------------|------------|-------------|------------|
| Hotel      | ●●●●●●●●●● | Fish market | ●●●●●●●●●● |
| Restaurant | ●●●●●●●●●● | Supermarket | ●●●●●●●●●● |
| Fast food  | ●●●●●●●●●● | SPA         | ●●●●●●●●●● |
| Bar        | ●●●●●●●●●● | Medical     | ●●●●●●●●●● |
| Disco      | ●●●●●●●●●● | Industry    | ●●●●●●●●●● |

### • Features & Plus

- Compact and longlasting nuggets
- Low consumption (1 liter water / 1 kg ice) - aircooled vers.
- Electromechanical functioning
- External structure AISI 304 Scotch Brite
- Evaporator AISI 304, auger AISI 303 made
- Air Cooling and Water Cooling systems
- Standard and special voltages
- Insulated retractable door
- ON-OFF switch
- Dust proof water basin
- Easy cleaning thanks to rounded surfaces
- External protective filter, removable, easy to clean
- Internal bin insulation HCFC free
- Conformity to RoHS directive
- Automatic water charge
- Model in Tropical Class + 43 ° C
- Undercounter model

### • Available pebble size

Drawing for reference only

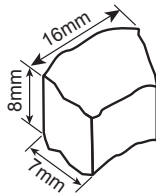

### • Prod. 24h

| Air temp. | Water temp. | Prod. 24h kg |
|-----------|-------------|--------------|
| 10° C     | 10° C       | 96           |
| 21° C     | 15° C       | 85           |
| 32° C     | 21° C       | 71           |

## 2 Years Warranty

subject to limitations

### • Certifications available for this model



www.ntfice.it  
info@ntfice.it



ntfice.it



# SLT 170



## FROZEN STONE



Self-contained ice maker - Pebble system  
Daily production up to 96 kg

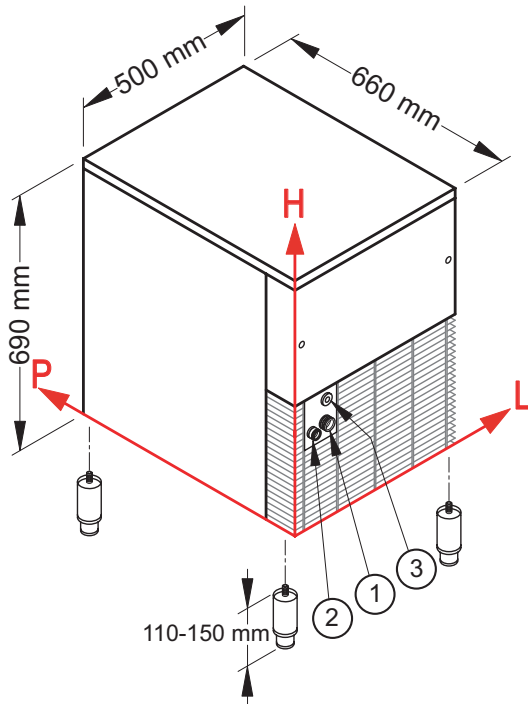

### • Connections

All measures are referred to the rear bottom-left corner (L-H-Ø)

- ① Water inlet:  
99 mm - 158 mm - 3/4"
- ② Water outlet:  
48 mm - 151 mm - 24 mm
- ③ Electrical connection:  
87 mm - 230 mm

### • Working conditions

- Location: Indoor

|                      | Min           | Max           |
|----------------------|---------------|---------------|
| Ambient temperature  | +10° C        | +43° C        |
| Water temperature    | +3° C         | +32° C        |
| Voltage              | -10%          | +10%          |
| Water inlet pressure | 1bar (14 psi) | 6bar (84 psi) |

### • Technical information

|                            |  |
|----------------------------|--|
| Production in 24h          | 85 kg                                  |
| Store capacity, up to      | 20 kg                                  |
| Cooling system             | A - W                                  |
| Approximate pebble size    | 8 x 16 x 7                             |
| Refrigerant                | R404A - R452A                          |
| Standard voltage           | 220-240 V ~ 50 Hz                      |
| Electrical consumption     | 550 W                                  |
| Fuse                       | 10 A                                   |
| Water consumption          | A: 1 l/kg<br>W: 6,3 l/kg               |
| Sizes (L-P-H mm)           | 500 - 660 - 690                        |
| Sizes with pack (L-P-H mm) | 550 - 720 - 880                        |
| Net weight                 | 59 kg                                  |
| Gross weight               | 67 kg                                  |
| Finish                     | AISI 304 stainless steel, scotch brite |

All the technical information must be considered at the following conditions:

|                    |                            |                          |   |
|--------------------|----------------------------|--------------------------|---|
|                    |                            |                          |   |
| Sizes without feet | Ambient temperature +21° C | Water temperature +15° C | Electrical consumption at +43° C (standard voltage) |

Models and specifications are subject to change without notice  
Rev. 02 - Issued September 2019



[www.ntfice.it](http://www.ntfice.it)  
[info@ntfice.it](mailto:info@ntfice.it)



ntfice.it

