

# GM 2000 Split



## FROZEN SNOW



Modular ice maker - Granular system  
Daily production 1000 kg

### ● Position n°



### ● Application fields

Hotel	●●●●●●●●●●	Fish market	●●●●●●●●●●
Restaurant	●●●●●●●●●●	Supermarket	●●●●●●●●●●
Fast food	●●●●●●●●●●	SPA	●●●●●●●●●●
Bar	●●●●●●●●●●	Medical	●●●●●●●●●●
Disco	●●●●●●●●●●	Industry	●●●●●●●●●●

### ● Features & Plus

- Granular ice
- 1 m<sup>3</sup> = 550 kg of ice
- Low consumption (1 liter water / 1 kg ice)
- External structure AISI 304 Scotch Brite
- Monoblock Stainless steel frame
- Evaporator AISI 304, auger AISI 303 made
- Standard and special voltages
- ON-OFF switch
- Dust proof water basin
- Rotation sensor directly on evaporator
- Conformity to RoHS directive
- Automatic water charge
- Model in Tropical Class + 43 ° C

### ● Usable Bins

- Bin 1200DD
- DRB 1100
- DRB 2500

**2 Years  
Warranty**

subject to limitations

### ● Certifications available for this model



[www.ntfice.it](http://www.ntfice.it)  
[info@ntfice.it](mailto:info@ntfice.it)



[ntfice.it](http://ntfice.it)



# GM 2000 Split



## FROZEN SNOW



Modular ice maker - Granular system  
Daily production 1000 kg

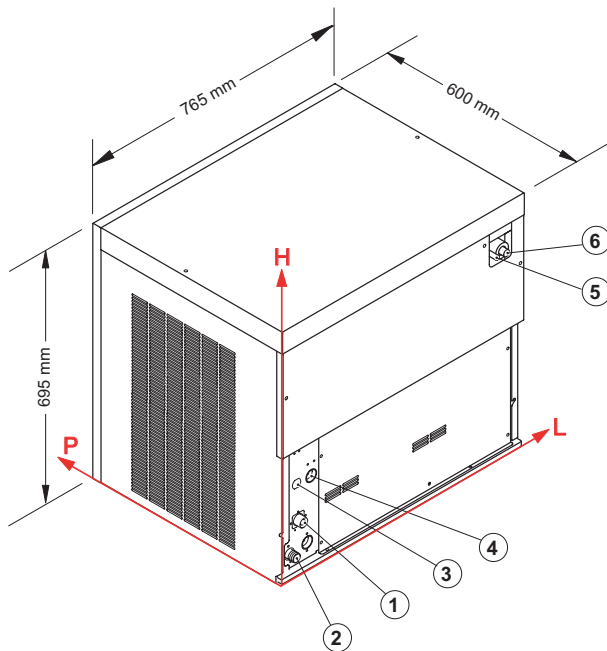

### • Connections

All measures are referred to the rear bottom-left corner (L-H-Ø)

- ① Water inlet:  
71 mm - 140 mm - 3/4"
- ② Water Outlet:  
44 mm - 60 mm - 24 mm
- ③ Remote connection:  
111 mm - 240 mm
- ④ Electrical connection:  
67 mm - 240 mm
- ⑤ Refrigerant feeding pipe
- ⑥ Outlet pipe of gaseous refrigerant

### • Working conditions

- Location: Indoor

	Min	Max
Ambient temperature	+10° C	+43° C
Water temperature	+3° C	+32° C
Voltage	-10%	+10%
Water inlet pressure	1bar (14 psi)	6bar (84 psi)

### • Technical information

Production in 24h	1000 kg
Refrigerant	R404A - R507 - R448A - R449A - R407F - R452A
Refrigerant capacity	4600 W (evap. temp. -18° C)
Standard voltage	220-240 V ~ 50 Hz
Electrical consumption	350 W
Sizes (L-P-H mm)	765 - 600 - 695
Sizes with pack (L-P-H mm)	860 - 690 - 890
Net weight	118 kg
Gross weight	132 kg
Finish	AISI 304 stainless steel, scotch brite

All the technical information must be considered at the following conditions:



Refrigerant capacity  
2300 W  
(evap. temp. -18° C)



Water temperature  
+15° C



Electrical consumption  
at +43° C  
(standard voltage)

Models and specifications are subject to change without notice  
Rev. 02 - Issued September 2019

