

SM 4500



FROZEN ICE



Modular ice maker - Scale system
Daily production up to 2450 kg

• Position n°



• Application fields

| | | | |
|------------|------------|-------------|------------|
| Hotel | ●●●●●●●●●● | Fish market | ●●●●●●●●●● |
| Restaurant | ●●●●●●●●●● | Supermarket | ●●●●●●●●●● |
| Fast food | ●●●●●●●●●● | SPA | ●●●●●●●●●● |
| Bar | ●●●●●●●●●● | Medical | ●●●●●●●●●● |
| Disco | ●●●●●●●●●● | Industry | ●●●●●●●●●● |

• Features & Plus

- Subcooled flakes (from -5°C to -10°C)
- Low consumption (1 liter water / 1 kg ice)
- Electromechanical functioning
- External structure AISI 304 Scotch Brite
- Stainless steel frame
- Evaporator anticorodal alloy made, with rotating knife
- Air Cooling and Water Cooling systems
- Standard and special voltages
- 1 m³ = 430 kg of ice
- ABS plastic components, FDA approved
- Easy cleaning thanks to rounded surfaces
- Cleanable antiscaling filter
- Removable and cleanable air filter
- Conformity to RoHS directive
- Automatic water charge
- Model in Tropical Class + 43 °C

• Prod. 24h

| Air temp. | Water temp. | Prod. 24h kg |
|-----------|-------------|--------------|
| 10° C | 10° C | 2450 |
| 21° C | 15° C | 2300 |
| 32° C | 21° C | 2034 |

2 Years Warranty

subject to limitations

• Certifications available for this model



www.ntfice.it
info@ntfice.it



ntfice.it



SM 4500



FROZEN ICE



Modular ice maker - Scale system
Daily production up to 2450 kg

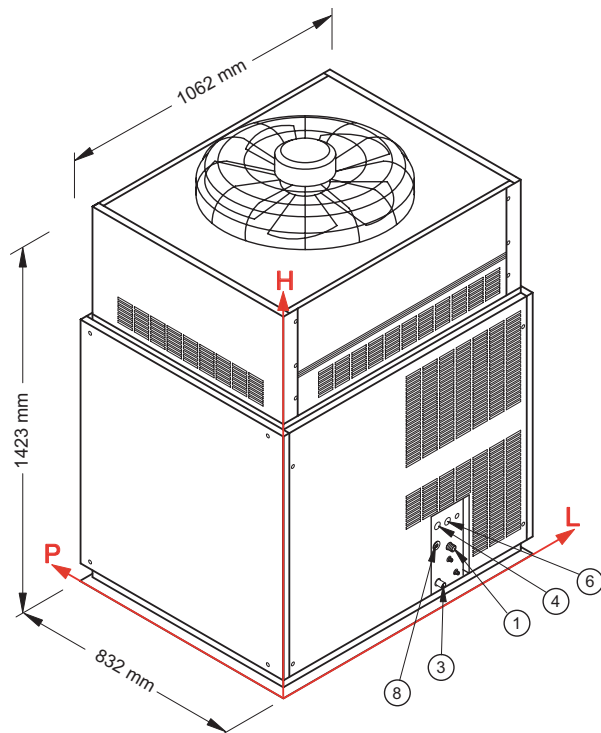

• Connections

All measures are referred to the rear bottom-left corner (L-H-Ø)

- ① Water inlet:
684 mm - 192 mm - 3/4"
- ③ Water outlet:
659 mm - 65 mm - 24 mm
- ④ Electrical connection:
651 mm - 271 mm
- ⑥ Remote connection:
693 mm - 271 mm
- ⑧ Connection to saline solution dosing pump:
640 mm - 232 mm

• Working conditions

- Location: Indoor

| | Min | Max |
|----------------------|---------------|---------------|
| Ambient temperature | +10° C | +43° C |
| Water temperature | +3° C | +32° C |
| Voltage | -10% | +10% |
| Water inlet pressure | 1bar (14 psi) | 6bar (84 psi) |

• Technical information

| | |
|----------------------------|--|
| Production in 24h | 2300 kg |
| Cooling system | A |
| Refrigerant | R404A - R452A |
| Standard voltage | 400-415 V ~ 3N 50 Hz |
| Electrical consumption | 7000 W |
| Fuse | 32 A |
| Water consumption | 1 l/kg |
| Sizes (L-P-H mm) | 1062 - 832 - 1423 |
| Sizes with pack (L-P-H mm) | 1150 - 960 - 1700 |
| Net weight | 520 kg |
| Gross weight | 570 kg |
| Finish | AISI 304 stainless steel, scotch brite |

All the technical information must be considered at the following conditions:



Ambient temperature
+21° C



Water temperature
+15° C



Electrical consumption
at +21° C
(standard voltage)

Refrigerant R404A

Models and specifications are subject to change without notice
Rev. 01 - Issued May 2018



www.ntfice.it
info@ntfice.it



ntfice.it

