

GM 1500
Split CO₂



FROZEN SNOW



Modular ice maker - Granular system
Daily production 720 kg

● Position n°



● Application fields

| | | | |
|------------|------------|-------------|------------|
| Hotel | ●●●●●●●●●● | Fish market | ●●●●●●●●●● |
| Restaurant | ●●●●●●●●●● | Supermarket | ●●●●●●●●●● |
| Fast food | ●●●●●●●●●● | SPA | ●●●●●●●●●● |
| Bar | ●●●●●●●●●● | Medical | ●●●●●●●●●● |
| Disco | ●●●●●●●●●● | Industry | ●●●●●●●●●● |

● Features & Plus

- Granular ice
- 1 m³ = 550 kg of ice
- Low consumption (1 liter water / 1 kg ice)
- External structure AISI 304 Scotch Brite
- Monoblock Stainless steel frame
- Evaporator AISI 304, auger AISI 303 made
- Standard and special voltages
- ON-OFF switch
- Dust proof water basin
- Rotation sensor directly on evaporator
- Conformity to RoHS directive
- Automatic water charge
- Model in Tropical Class + 43 ° C
- Pressure limiting valve, PS up to 40 bar

● Usable Bins

- Bin PE530
- Bin T250
- Bin T420
- Bin T830
- Bin 1200DD
- RB 140
- RB 280
- DRB 1100
- DRB 2500

2 Years
Warranty

subject to limitations

● Certifications available for this model



www.ntfice.it
info@ntfice.it



ntfice.it



GM 1500 Split CO₂



FROZEN SNOW



Modular ice maker - Granular system
Daily production 720 kg

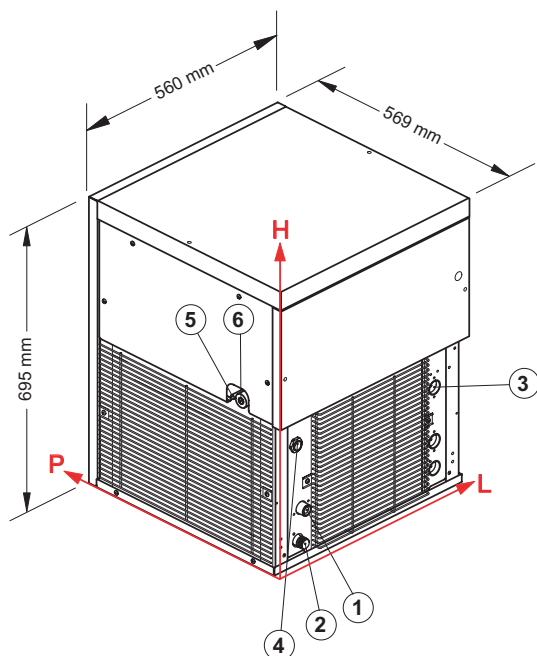

• Connections

All measures are referred to the rear bottom-left corner (L-H-Ø)

- ① Water inlet:
85,5 mm - 130 mm - 3/4"
- ② Water Outlet:
75,5 mm - 55 mm - 24 mm
- ③ Remote connection:
479,5 mm - 260 mm
- ④ Electrical connection:
67,5 mm - 290 mm
- ⑤ Refrigerant feeding pipe
- ⑥ Outlet pipe of gaseous refrigerant

• Working conditions

- Location: Indoor

| | Min | Max |
|----------------------|---------------|---------------|
| Ambient temperature | +10° C | +43° C |
| Water temperature | +3° C | +32° C |
| Voltage | -10% | +10% |
| Water inlet pressure | 1bar (14 psi) | 6bar (84 psi) |

• Technical information

| | |
|----------------------------|--|
| Production in 24h | 720 kg |
| Refrigerant | CO ₂ (R744) |
| Refrigerant capacity | 2300 W (evap. temp. -18° C) |
| PS suction side | 580 PSI - 40bar |
| Standard voltage | 220-240 V ~ 50 Hz |
| Electrical consumption | 175 W |
| Sizes (L-P-H mm) | 560 - 569 - 695 |
| Sizes with pack (L-P-H mm) | 645 - 645 - 910 |
| Net weight | 67 kg |
| Gross weight | 77 kg |
| Finish | AISI 304 stainless steel, scotch brite |

All the technical information must be considered at the following conditions:



Refrigerant capacity
2300 W
(evap. temp. -18° C)



Water temperature
+15° C



Electrical consumption
at +43° C
(standard voltage)

Models and specifications are subject to change without notice
Rev. 01 - Issued May 2018

